



REGENERATION  
PROCESS

**ROCKET**  
RENTALS

**JCB 3T, 6T  
& 9T DUMPERS**  
Specification Sheet

Rocket Rentals is a one stop shop for all  
your plant, access & tool hire needs.

[www.rocketrentals.co.uk](http://www.rocketrentals.co.uk)

All of our JCB equipment is supplied by Holt JCB

HOLT JCB



STATIC DIMENSIONS AND CAPACITIES

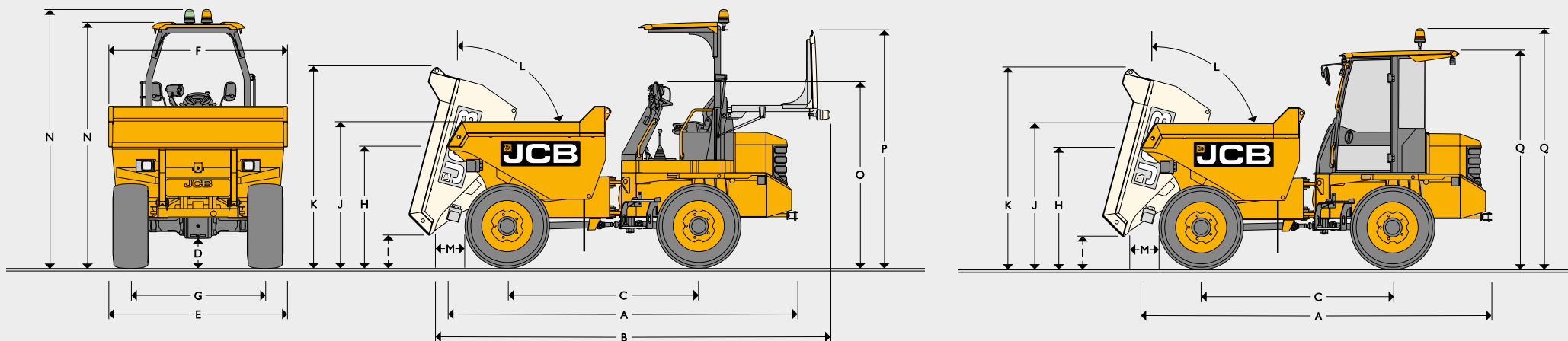

STATIC DIMENSIONS AND CAPACITIES

		1T-2 HT	3T-2 FT	3T-2 ST	6T-2 FT	6T-2 ST	6T SiTESAFE Skip	9T-2 FT	9T SiTESAFE Skip
A	Overall length	mm	3095	3758	3926	4792	5047	4912	4918
B	Overall length (ROPS or FOPS folded)	mm	3403	4192	4360	5023	5280	5141	5158
C	Wheelbase	mm	1500	1950	1950	2480	2480	2680	2880
D	Minimum ground clearance	mm	263	206	206	312	312	359	362
E	Total width (Standard/Narrow tyres)	mm	1106/980	1650	1650	2255	2255	2380	2500
F	Skip width	mm	980	1650	1654	2310	2018	2300	2500
G	Track width (Standard/Narrow tyres)	mm	850/782	1360	1360	1850	1850	2225	2380
I	Height to front lip of skip (untipped)	mm	1134/2259	1367	1467	1672	1719	1523	1558
H	Height to front lip of skip (tipped)	mm	452/1573	306	856	310	1122	508	694
J	Load over height	mm	1268/2392	1504	1567	1791	2028	2150	2318
K	Height over skip (tipped)	mm	1865/3037	2085	2860	2411	3674	2456	2732
L	Skip tip angle	Degrees	90	75	67	80	70	75	80
M	Discharge distance front	mm	391	568	548	604	582	580	526
	Discharge distance side	mm	N/A	N/A	319	N/A	241	N/A	N/A
	Turning radius to outside of skip	mm	2712	5448	4573	5900	5777	5645	6372
	Turning radius to outside of tyres	mm	2559	4464	4464	5755	5739	5526	6218
	Steering angle (+/-)	Degrees	39	30	30	30	30	34	30
	Oscillation	Degrees	15	10.5	10.5	10	10	10	10
N	Height to top of ROPS (with/without beacon)	mm	2792/2602	3016/2835	3016/2835	3354/3131	3354/3131	3354/3131	3570/3347
N	Height to top of ROPS/FOPS (with/without beacon)	mm	N/A	N/A	N/A	3354/3169	3354/3169	3354/3169	3570/3385
O	Height with folded ROPS	mm	1624	1857	1857	2169	2169	2013	2319
P	Height with folded ROPS/FOPS	mm	N/A	N/A	N/A	2936	2936	2936	3154
Q	Height to top of cab (with/without beacon)	mm	N/A	N/A	N/A	3296/3014	3296/3014	3296/3014	3512/3230

\*With high tip mechanism raised.

<b>CAPACITIES</b>									
		1T-2 HT	3T-2 FT	3T-2 ST	6T-2 FT	6T-2 ST	6T SiTESAFE Skip	9T-2 FT	9T SiTESAFE Skip
Payload	kg	1000	3000	3000	6000	6000	6000	9000	9000
Operating weight - ISO6016 full tank of fuel & 75kg operator (ROPS)	kg	1515	2345	2390	4840	5070	5040	5400	5085
Operating weight - ISO6016 full tank of fuel & 75kg operator (ROPS/FOPS)	kg	N/A	N/A	N/A	4920	5150	4960	5480	5165
Operating weight - ISO6016 full tank of fuel & 75kg operator (Cab)	kg	N/A	N/A	N/A	5180	5410	5220	5740	5425
Tipping type		Front tip - high tip	Front tip	Swivel tip	Front tip	Swivel tip	Front tip	Front tip	Front tip
Skip Capacity (fluid)	l	307	1050	930	1974	1615	1900	2435	2170
Skip Capacity (struck)	l	454	1420	1237	2537	2514	2725	3735	3720
Skip capacity (heaped)	l	554	1723	1615	3191	3149	3300	4531	4300

<b>ENGINE</b>									
		1T-2 HT	3T-2 FT	3T-2 ST	6T-2 FT	6T-2 ST	6T SiTESAFE Skip	9T-2 FT	9T SiTESAFE Skip
Engine model		Perkins 403J.II	Perkins 403J-17				JCB DieselMAX		
Capacity	cc	1131	1662				3000		
Aspiration		Naturally Aspirated	Naturally Aspirated				Turbocharged		
Cylinders		3	3				4		
Max. gross power to SAE J1995/ISO 14396	kW (hp)	16.1 (21.6)	18.9 (25.3)				55 (74)		
Max. torque	Nm	66.8	87.2				440		
Emissions compliance		EU Stage V / Tier 4 Final	Stage V				Stage V		

<b>TRANSMISSION</b>									
		1T-2 HT	3T-2 FT	3T-2 ST	6T-2 FT	6T-2 ST	6T SiTESAFE Skip	9T-2 FT	9T SiTESAFE Skip
Type		Hydrostatic pump to 4 hydraulic wheel motors	Hydrostatic motor via transfer box to front and rear axles				Powershuttle		
Tyre size		"255/75 x 15.3 x 8 ply (option 7.0 x 12 narrow tyre)"	295/80 x 15.3 (10 ply)		405-70-20 14PR		500-60-22.5 16PR		
Drive		Hydrostatic I/I	"2/2 (High and low range - forward and reverse) Hydrostatic - permanent 4WD"				4/4 Forward and reverse - permanent 4WD		
Max. travel speed (unladen) 1st gear	mph (kph)	7.4 (11.9)	5.0 (8) - Tortoise		3.1 (5.0)		2.8 (4.5)		
Max. travel speed (unladen) 2nd gear	mph (kph)	-	13 (21) - Hare		5.0 (8.1)		4.7 (7.5)		
Max. travel speed (unladen) 3rd gear	mph (kph)	-	-		9.4 (15.2)		8.8 (14.1)		
Max. travel speed (unladen) 4th gear	mph (kph)	-	-		15.9 (25.6)		15.3 (24.7)		

**ELECTRICAL SYSTEM**

		1T-2 HT	3T-2 FT	3T-2 ST	6T-2 FT	6T-2 ST	6T SiTESAFE Skip	9T-2 FT	9T SiTESAFE Skip
System voltage	V				12				
Alternator output	A	40	65				95		
Battery capacity	Ah	80	62				110		

**SERVICE FILL CAPACITIES**

		1T-2 HT	3T-2 FT	3T-2 ST	6T-2 FT	6T-2 ST	6T SiTESAFE Skip	9T-2 FT	9T SiTESAFE Skip
Hydraulic tank	l	28	35				60		
Fuel tank	l	30	35				65		

**BRAKING**

		1T-2 HT	3T-2 FT	3T-2 ST	6T-2 FT	6T-2 ST	6T SiTESAFE Skip	9T-2 FT	9T SiTESAFE Skip
Working brake		Hydrostatic dynamic braking on rear wheel motors	Multi-plate in-board oil immersed discs on front axle				Foot brake-oil immersed discs on front/rear		
Parking brake		Hydrostatic dynamic braking on rear wheel motors	Over centre handbrake-oil immersed discs on front axle				Over centre parking brake-dry disc on gearbox		

OPTIONS	IT-2	3T-2	6T-2	9T-2
Folding ROPS frame	●	●	●	●
Folding ROPS/FOPS Lvl II frame	■	■	+	+
JCB SITESAFE Cab (ROPS/FOPS Level II) with heater and protective front screen	■	■	+	+
JCB SITESAFE Cab (ROPS/FOPS Level II) with heater, air cooling and protective front screen	■	■	+	+
Front Screen Guard (Only available with Cab)	■	■	+	+
Skip Guard	■	■	+	+
Reverse alarm	●	●	●	●
White Noise reverse alarm	+	+	+	+
Dual circuit breaking	■	■	●	●
Speedometer	■	■	●	●
Tie-down and lifting points	●	●	●	●
Lap belt (high-visibility orange, emergency locking retractor)	●	●	●	●
LED amber beacon	●	●	●	●
LED green beacon	●	●	●	●
Sequenced drive inhibit system	●	●	●	●
Audible alarm on initial machine movement (horn sounds twice)	●	●	●	●
Skip raised audible alarm	■	■	+	+
Seat adjustment: fore/aft, operator weight, back angle	●	●	●	●
Recovery hitch	■	●	●	●
Tow bar	■	■	+	+
Full width steering column protection	●	●	●	●
CESAR Datatag security (UK only)	●	●	●	●
Traction tyres	●	●	●	●
Narrow tyres	+	■	■	■
Wide Track	+	■	■	■
Turf tyres	■	■	+	■
High visibility steps and grab handles	+	+	+	+
Flexible steps	■	■	+	+
Rear view mirrors	+	+	+	+
Road lights	+	+	+	+
LED work lights (front and rear)	+	+	+	+
Three speed only restriction	■	■	+	+
Object detection system (requires front camera fitment)	■	■	+	+
Front Camera (Not standard on SITESAFE skip variants)	■	■	●	●
Side/Rear Cameras (requires front camera fitment)	■	■	+	+
LiveLink telematics	+	+	●	●
Rental ready decals - clear skip sides	+	+	+	+
Front bumper bar	+	■	■	■
Loose decals	■	+	+	+
Spare tyre	+	+	+	+
SMART Safety pack	+	■	■	■

- Standard
- + Option
- Not available



Proud to stock a number of  
JCB ranges including:

**TRACKED EXCAVATORS**

**TELEHANDLERS**

**SITE DUMPERS**

**TANDEM ROLLERS**

**GENERATORS**

**ROCKET  
RENTALS**

For more information, visit our  
website at [www.rocketrentals.co.uk](http://www.rocketrentals.co.uk)

For plant hire services in the  
Gloucester area, get in touch with  
the team at Rocket Rentals Ltd. on:

**Plant and Access Hire**  
01453 51 95 51  
[hire@rocketrentals.co.uk](mailto:hire@rocketrentals.co.uk)

**Tool Hire**  
01453 51 94 51

**Accounts**  
01453 51 95 51  
[accounts@rocketrentals.co.uk](mailto:accounts@rocketrentals.co.uk)