



ROCKET
RENTALS

JCB 514-40 Telehandler
Specification Sheet

Rocket Rentals is a one stop shop for all
your plant, access & tool hire needs.

www.rocketrentals.co.uk

All of our JCB equipment is supplied by Holt JCB

HOLT JCB



STATIC DIMENSIONS

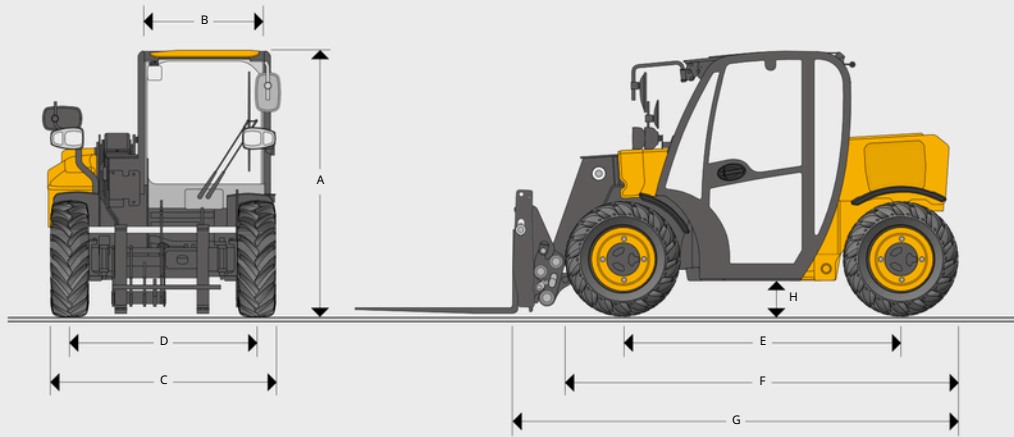

Machine model		514-40
A Overall height	m	1.80
B Inside width of cab	m	0.87
C Width over tyres	m	1.56
D Front track	m	1.29
E Wheelbase	m	1.88
F Overall Length to front tyres	m	2.61
G Overall length to front carriage	m	2.99
H Ground clearance	m	0.19
Outer turn radius over tyres	m	2.81
Carriage roll back angle at ground	degrees	12/30*
Carriage dump angle at max height	degrees	35
Weight (operating weight)	kg	2915
Weight (unladen with forks & frame)	kg	2840
Weight (unladen, no attachment)	kg	2700
Tyres	turf	10 x16 . 5
	industrial	12 x16 . 5

*Bucket.

LIFT PERFORMANCE

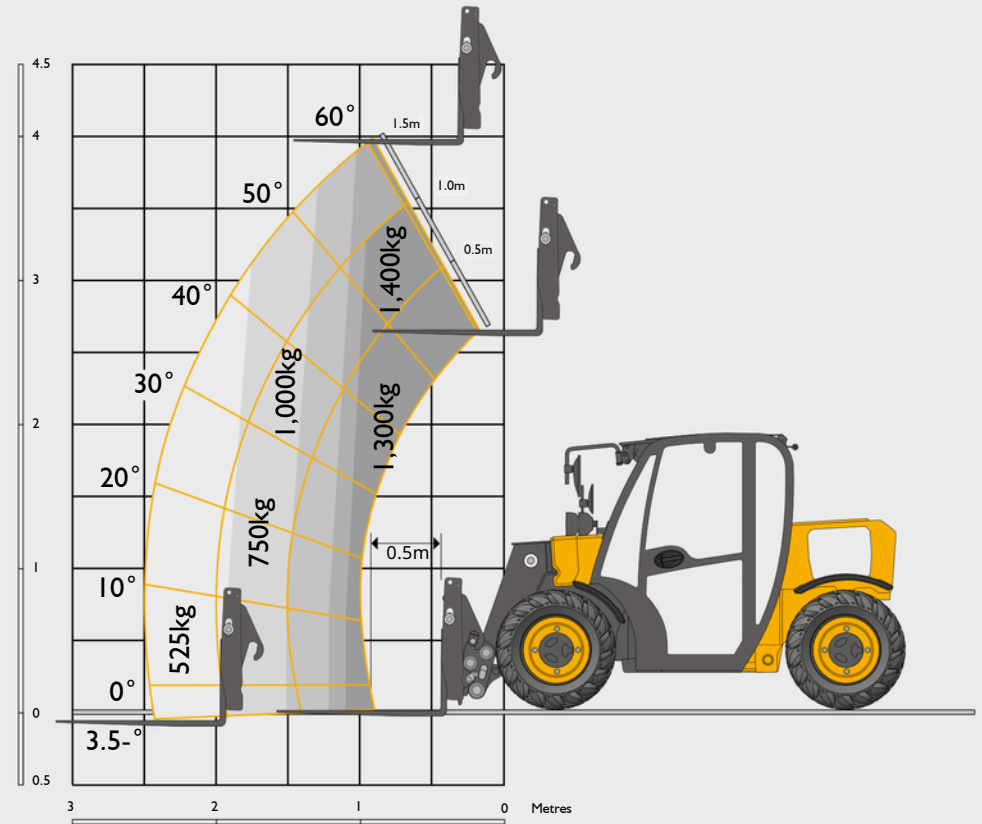

Machine model		514-40
Maximum lift capacity	kg	1400
Lift capacity to full height	kg	1300
Lift capacity at full reach	kg	525
Maximum lift height	mm	4035
Reach at max. lift height	mm	890
Maximum forward reach	mm	2510
Reach with 1 tonne payload	mm	1510
Complies with stability test EN 1459 Annex B.	mm	

ENGINE				
	514-40	516-40	520-40	525-60 Hi-Viz
Engine model	Perkins 403J-11	Perkins 403J-17	Perkins 403J-17	JCB Diesel by Kohler
Power kW	18.4	18.4	18.4	55
Torque Nm	66.9Nm @ 1400rpm	98Nm @ 1400rpm	98Nm @ 1400rpm	300Nm @1500rpm
Displacement litres	1.1	1.7	1.7	2.5
Number of cylinders	3	3	3	4

TRANSMISSION				
	514-40	516-40	520-40	525-60 Hi-Viz
Type	Hydrostatic			
Modes	2 Speed			
Drive	Permanent 4 Wheel Drive			
Maximum speed kph	15	15	15	25

ELECTRICAL SYSTEM				
	514-40	516-40	520-40	525-60 Hi-Viz
System voltage Volt	12	12	12	12
Alternator output Amp hour	62	85	85	100
Battery capacity Amp hour	65	80	80	120

HYDRAULICS				
	514-40	516-40	520-40	525-60 Hi-Viz
Maximum system pressure bar	230	230	230	260
Flow rate ltr/min	23	40	40	80
Joystick control	Twin lever	Single lever	Twin lever	Single lever Servo
Steer modes	Permanent 4 Wheel Steer			3 modes
Cycle times				
Boom Raise seconds	7	8.9	8.9	7.6
Boom Lower seconds	5	4.9	5.9	5.3
Extend seconds	8.6	6.6	4.7	7.5
Retract seconds	4.3	3.7	4.7	3.7
Bucket Dump seconds	2.7	4.2	4.8	1.9
Bucket Crowd seconds	3.7	3	4	2.9

SERVICE CAPACITIES					
		514-40	516-40	520-40	525-60 Hi-Viz
Fuel tank	litres	27	50	61	65
Hydraulic tank	litres	25	58	33	75

BRAKES				
	514-40	516-40	520-40	525-60 Hi-Viz
Service brakes	Hydraulically operated self-adjusting			
Parking brake	Cable manually operated drum brake			SAHR Handbrake self adjusting

OPTIONS				
	514-40	516-40	520-40	525-60 Hi-Viz
CAB				
ROPS ISO3471	•	•	•	•
FOPS ISO 3449	•	•	•	•
Hourmeter	•	•	•	•
Adjustable fabric seat	•	•	•	•
Digital dash display	•	•	•	•
LiveLink telematics	•	•	•	•
Load control system (LMI)	•	•	•	•

ACCESSORIES				
	514-40	516-40	520-40	525-60 Hi-Viz
Reversing alarm	•	•	•	•
50mm towing ball with 7 pin trailer electrics	•	-	-	-
Halogen work lights	-	+	+	+
LED work lights	+	-	-	+
Amber beacon	+	+	+	+
Green beacon with orange seat belt	+	-	+	+
Competitor carriages	+	+	+	+
Window guards	-	+	+	+
Sun blind	+	+	+	+
Immobiliser	+	+	+	+
Air conditioning	-	-	-	+
FM radio kit	+	+	+	+

STANDARD •

OPTIONAL +

NOT APPLICABLE -



Proud to stock a number of JCB ranges including:

TRACKED EXCAVATORS

TELEHANDLERS

SITE DUMPERS

TANDEM ROLLERS

GENERATORS

ROCKET
RENTALS

For more information, visit our website at www.rocketrentals.co.uk

For plant hire services in the Gloucester area, get in touch with the team at Rocket Rentals Ltd. on:

Plant and Access Hire
01453 51 95 51
hire@rocketrentals.co.uk

Tool Hire
01453 51 94 51

Accounts
01453 51 95 51
accounts@rocketrentals.co.uk